

S. F. PERKINS.

KITE.

APPLICATION FILED JAN. 25, 1917.

1,222,791.

Patented Apr. 17, 1917.

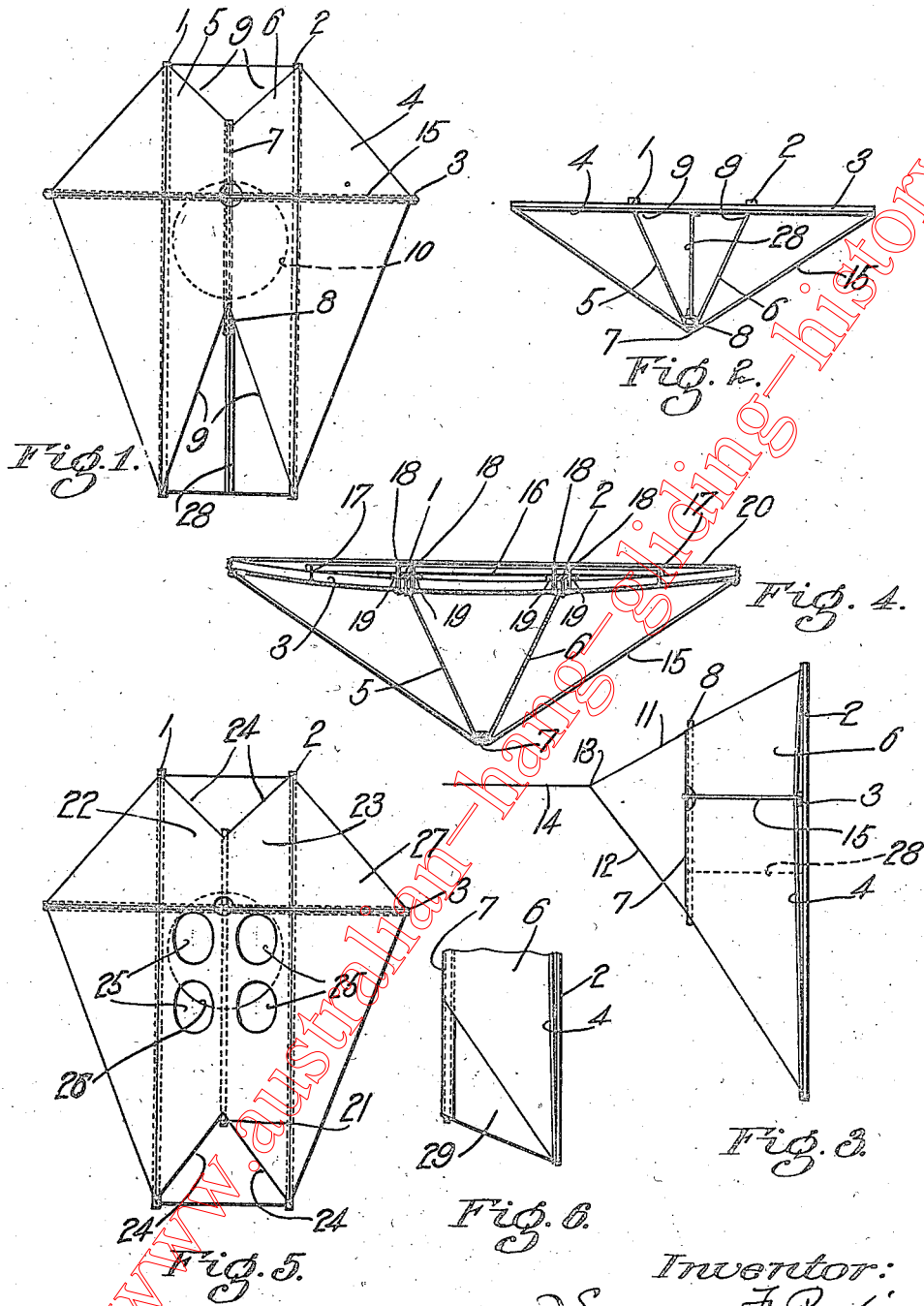

Inventor:  
Samuel F. Perkins  
By Charles N. Gooding

# UNITED STATES PATENT OFFICE.

SAMUEL F. PERKINS, OF BOSTON, MASSACHUSETTS.

## KITE.

1,222,791.

Specification of Letters Patent. Patented Apr. 17, 1917.

Application filed January 25, 1917. Serial No. 144,520.

### To all whom it may concern:

Be it known that I, SAMUEL F. PERKINS, a citizen of the United States, residing at Boston, in the county of Suffolk and State of Massachusetts, have invented new and useful Improvements in Kites, of which the following is a specification.

This invention relates to improvements in kites and has for its object to provide an inexpensive, powerful kite provided with suitable balancing and steadying means, permitting the use of the kite for the purpose of carrying men and loads of considerable weight.

The invention consists in the combination and arrangements of parts set forth in the following specification and particularly pointed out in the claims.

Referring to the drawings:

Figure 1 is a front elevation of a kite embodying my invention.

Fig. 2 is a plan view of the same.

Fig. 3 is a side elevation of the same.

Fig. 4 is a section taken substantially along the cross stick of a modified form of kite.

Fig. 5 is a front elevation of a slightly modified form of kite.

Fig. 6 is a detail side view of the lower portion of a kite similar in form to that illustrated in Figs. 1 to 3 inclusive but illustrating a modified form of fin.

Like numerals refer to like parts throughout the several views of the drawings.

In the drawings, 1 and 2 represent a pair of parallel upright sticks. 3 represents a third stick disposed substantially at right angles to the sticks 1 and 2 and approximately one-third distance from the upper ends of said parallel sticks, said several sticks being secured together at their crossing points.

A sheet of suitable material, preferably cloth 4, is arranged over one face of the frame formed by the sticks, 1, 2 and 3, said sheet being attached to the opposite ends of said sticks and having an outline coinciding with a figure represented by a line circumscribing said frame and connecting the extremities of said sticks.

Extending forwardly from each of the sticks 1 and 2 is a plane 5 and 6 respectively, substantially coextensive with said sticks. These planes are arranged to unite along a line 7 disposed equidistant from the sticks 1 and 2. A fourth stick 8 is se-

cured to the planes 5 and 6 along the juncture line 7 of said planes and reinforces or stiffens the edge made by said planes.

The stick 8 is substantially shorter than the sticks 1 and 2 and the planes 5 and 6 gradually decrease in length from that of said sticks 1 and 2 to that of the stick 8. By cutting away the planes 5 and 6, as stated, wind pockets may be formed at 9, 9 beneath the opposite ends of both of said planes which tend to steady the kite, when in the air, from wind striking against the outer faces of the planes 5 and 6.

The sheet 4 has an opening 10 formed therein at the back of the planes 5 and 6 so that portions of the air which is caught within the pockets 9 may escape to relieve some of the pressure therein. The fourth stick 8 forms a support for a bridle consisting of cords 11 and 12 attached to opposite ends respectively of said stick 8 and uniting at 13, at which point the captive line 14 is attached.

The outer ends of the stick 3 may be reinforced or braced by means of a cord 15 extending from said outer ends forwardly to the stick 8 to which said cord may be secured. This cord also assists in maintaining the stick 8 central with respect to the sheet 4 when the planes 5 and 6 are subjected to sudden gusts of wind.

Fig. 4 illustrates, in addition to the reinforcing cord 15, a reinforcing stick 16 nearly parallel with the stick 3 but upon the opposite face of the frame to that of said stick 3. The stick 16 is not quite as long as the stick 3 and its ends are slidably attached to said stick 3 preferably by suitable binding strands 17, 17 which permit a slight movement of said ends relatively to the stick 3.

The reinforcing stick 16 is furthermore securely bound at opposite sides of each of the sticks 1 and 2 by suitable binding strands, 18, 18 which are wound a number of times about the sticks 16 and 3 over separating blocks 19 that are inserted at opposite sides of the sticks 1 and 2. The strands 18, after being wound tightly in place, may be covered with a coating of some suitable preservative, such as varnish or the like and thereby provide a very strong and durable joint which eliminates the necessity of nailing the sticks together at their crossing points, which nailing would materially weaken said sticks.

A cord 20 is stretched from opposite ends of the stick 3, Fig. 4, and maintains said stick in a slightly arched state thus presenting a convex surface to the wind.

5 In Fig. 5 I have shown a structure similar to that shown in Fig. 4 with the exception that the stick 21, which is attached to the planes 22 and 23 corresponding to the planes 5 and 6 of Fig. 1, along the juncture line  
10 of said planes, is of somewhat greater length than the stick 8 of Fig. 1, but short enough to provide pockets 24, 24 at opposite ends of said planes 22 and 23.

The planes 22 and 23 are, in this form, provided with openings 25, 25 which are  
15 provided to relieve the pressure of wind against said planes and assist in steadying the kite in the air. One or more openings as at 26, may be provided in the sheet 27 in  
20 this form of kite at the rear of the planes 22 and 23 which also assists in relieving some of the pressure within the pocket formed by said planes.

The cutting away of the planes 5 and 6  
25 at their lower ends removes a considerable section of material which might otherwise assist in steadying the kite against lateral movement. This, however, is intended to be counteracted by the exposing of more of the  
30 interior surfaces of said planes and in producing longer pockets at 9 than would otherwise be possible.

To still further counteract the loss of  
35 area in the planes 5 and 6, due to the cutting away of said planes, a fin 28 is inserted between said planes and extends from the stick 8 to the sheet 4 to which it is secured preferably by stitching along a line midway between the sticks 1 and 2, thus maintaining  
40 said fin perpendicular to the sheet 4. The lower end of said fin may be cut away at an angle coinciding with the angle of the lower ends of the planes 5 and 6, as shown in Figs. 1 and 3, or, if desired, the stick 8 may be  
45 extended at its lower end, as shown in Fig. 6, permitting the fin 28 to be extended a considerable distance beyond the lower edges of said planes 5 and 6.

Having thus specifically described my invention what I claim and desire by Letters Patent to secure is:

1. A kite having, in combination, two parallel sticks, a third stick disposed at right  
55 angles to said parallel sticks and forming a frame, a sheet adapted to cover one face of said frame and secured to opposite ends of said sticks, a pair of planes extending forwardly from said parallel sticks and uniting along a line substantially shorter than and  
60 disposed parallel with said parallel sticks and equidistant from said sticks, said planes gradually decreasing in length from that of said parallel sticks to that of said uniting line, and means for reinforcing the forward  
65 edges of said planes.

2. A kite having, in combination, two parallel sticks, a third stick disposed at right angles to said parallel sticks and forming a frame, a sheet adapted to cover one face of said frame and secured to opposite ends of  
70 said sticks, a pair of planes secured to said parallel sticks substantially coextensive therewith, said planes extending forwardly and uniting along a line disposed equidistant from said parallel sticks, and a fourth  
75 stick substantially shorter than said parallel sticks and secured along the uniting line of said planes, said planes gradually decreasing in length from that of said parallel sticks to that of said fourth stick.

3. A kite having, in combination, two parallel sticks, a third stick disposed at right angles to said parallel sticks and forming a frame, a sheet adapted to cover one face of  
85 said frame and secured to opposite ends of said sticks, a pair of planes secured to said parallel sticks substantially coextensive therewith, said planes extending forwardly and uniting along a line disposed equidistant from said parallel sticks, and a fourth  
90 stick substantially shorter than said parallel sticks and secured along the uniting line of said planes, said planes gradually decreasing in length from that of said parallel sticks to that of said fourth stick, said planes  
95 also having openings adapted to relieve a portion of the wind pressure thereagainst.

4. A kite having, in combination, two parallel sticks, a third stick disposed at right angles to said parallel sticks and forming a  
100 frame, a sheet adapted to cover one face of said frame and secured to opposite ends of said sticks, a pair of planes secured to said parallel sticks substantially coextensive therewith, said planes extending forwardly  
105 and uniting along a line disposed equidistant from said parallel sticks, and a fourth stick substantially shorter than said parallel sticks and secured along the uniting line of said planes, said planes gradually decreasing in  
110 length from that of said parallel sticks to that of said fourth stick, said planes also having openings adapted to relieve a portion of the wind pressure thereagainst, said sheet having an opening provided therein at  
115 the rear of said planes adapted to permit the escape of a portion of the wind passing beneath said planes.

5. A kite having, in combination, a pair of parallel sticks, a third stick disposed substantially at right angles to said parallel sticks, a reinforcing stick disposed parallel with said third stick upon the opposite sides  
120 of said parallel sticks, means for slidably securing the ends of said reinforcing stick to said third stick, means for binding said reinforcing stick and said third stick together upon opposite sides of each of said parallel sticks, a sheet adapted to cover the  
125 face of the frame formed by said sticks upon

the same side thereof with said third stick, a pair of planes extending forwardly from each of said parallel sticks and uniting along a line disposed parallel with and equidistant from each of said parallel sticks, and means to reinforce the united edges of said planes.

5 6. A kite having, in combination, two parallel sticks, a third stick disposed at right angles to said parallel sticks to form a frame, 10 a sheet attached to said frame, a pair of co-extensive planes extending laterally from said sheet and uniting at their outer edges along a line lying parallel with said pair of sticks and equidistant from said sticks, said 15 planes gradually decreasing in length from said sheet to said uniting line, and means for reinforcing the forward edges of said planes.

20 7. A kite having, in combination, two parallel sticks, a third stick disposed at right angles to said parallel sticks to form a frame,

a sheet attached to said frame, a pair of co-extensive planes disposed laterally of said sheet and attached respectively to said parallel sticks, the forward edges of said planes 25 being secured together along a line disposed parallel with said parallel sticks and equidistant therefrom, the lower ends of said pair of planes being cut off at an angle to said sheet, a fourth stick secured to the forward edges of said parallel planes adapted 30 to reinforce said edges, and a fin extending from the lower end of said fourth stick to said sheet and secured thereto midway between said pair of planes. 35

In testimony whereof I have hereunto set my hand in presence of two subscribing witnesses.

SAMUEL F. PERKINS.

Witnesses:

CHARLES S. GOODING,  
SYDNEY E. TAFT.

www.australian-hang-glidering-illustrations.com