

No. 646,375.

Patented Mar. 27, 1900.

W. A. EDDY.

KITE.

(Application filed Aug. 1, 1898.)

(No Model.)

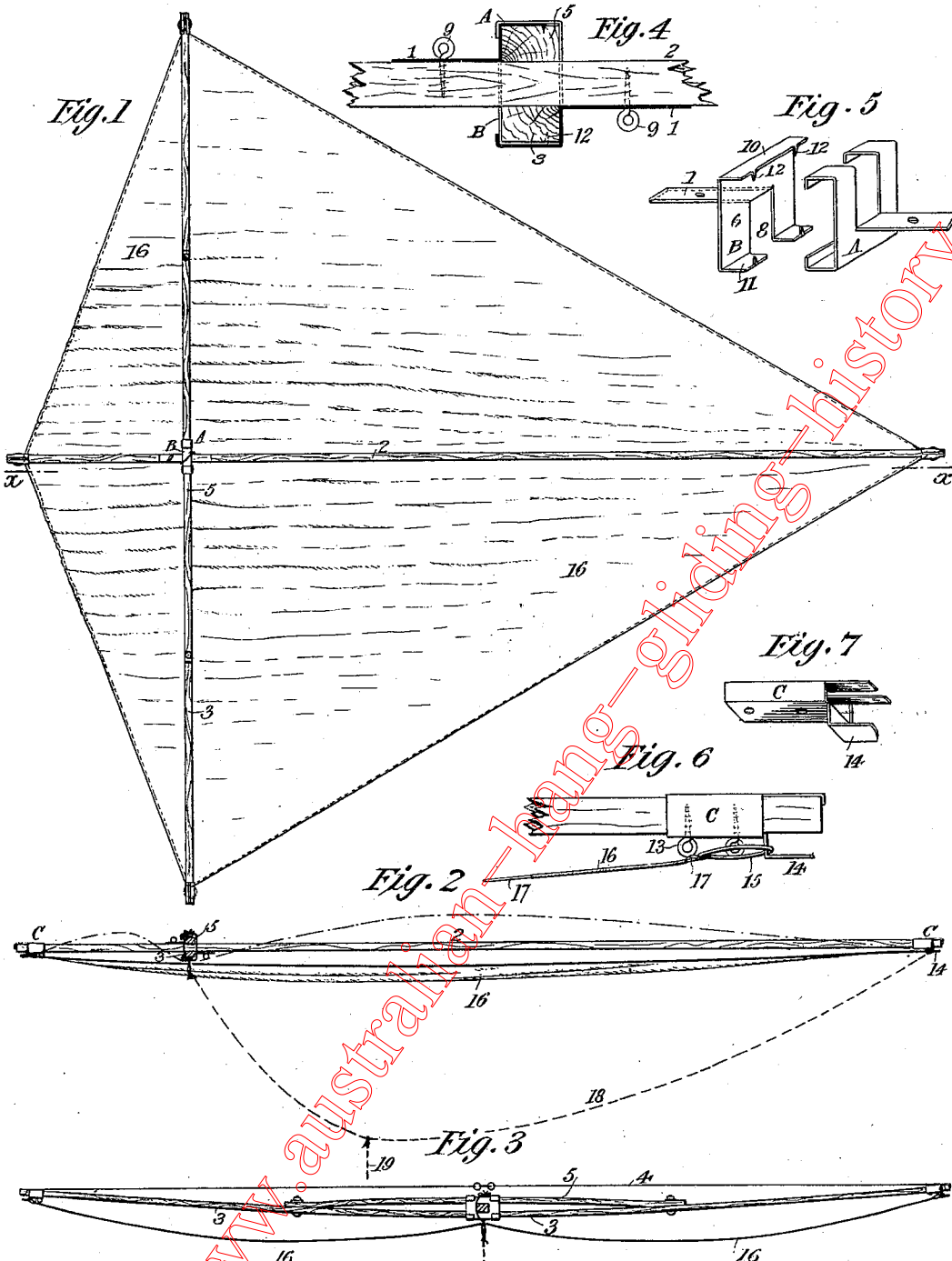

Witnesses:
Raphael Tetter
John A. Hesse.

William A. Eddy, Inventor
by T. D. Merwin Atty.

UNITED STATES PATENT OFFICE.

WILLIAM A. EDDY, OF BAYONNE, NEW JERSEY.

KITE.

SPECIFICATION forming part of Letters Patent No. 646,375, dated March 27, 1900.

Application filed August 1, 1898. Serial No. 687,394. (No model.)

To all whom it may concern:

Be it known that I, WILLIAM A. EDDY, of Bayonne, county of Hudson, State of New Jersey, have invented a new and useful Kite, of which the following is a specification.

My invention relates to improvements in kites, its object being to provide a superior form of tailless kite; and it consists in the features of construction hereinafter particularly described and claimed.

In the accompanying drawings, forming part of this specification, Figure 1 is a plan view of the rear or top face of the kite. Fig. 2 is a longitudinal section of the same on line XX of Fig. 1, showing in full and shade lines the natural sag or bagging of the fabric cover when the kite is supported horizontally and not in use, and by dot-and-dash lines the bellying of the cover under the pressure of the wind while in use, the broken line indicating the bridle by which the kite is held. Fig. 3 is a cross-section of the same, taken just in front of or above the cross-bar and looking toward the rear end of the kite, showing the slack of the cover and the construction of the cross-bar and the truss-wire which maintains the curvature of the cross-bar. Fig. 4 is a detail of the locking device for the joint at the intersection of the upright and cross bars. Fig. 5 shows in detached detail the clips for said joint. Fig. 6 is a detail of one of the ferrules for the ends of the bars, showing means for attaching the eye upon the kite-cover; and Fig. 7 is a detached detail of the same.

In the drawings, 2 represents the upright rectilinear bar or extender member which serves as a backbone for the kite.

3 is the cross-bar or extender member, preferably slightly curved, as shown, and positioned with the convex face presented forward or toward the wind. This bar is secured upon the upright at a point preferably about one-fifth of the length of the upright from its top, thus giving the most satisfactory results in actual service. The curvature of the cross-bar is maintained by means of the truss-wire 4, the tension of which may be adjusted at will to produce or maintain any desired curvature. On the rear or concave side of the cross-bar is a brace 5, which serves as the chord of an inner arc of the

curve of the cross-bar and strengthens the latter at its weakest point—namely, the junction with the upright. This brace may be a separate piece, fastened at each end equidistant from the center of the cross-bar, as shown in Fig. 3, or may be made up of two pieces overlapping, so that one serves as a brace for the other. The coupling at the intersection of the upright and cross-bar is shown best in Figs. 4 and 5. The upright passes between the cross-bar 3 and the brace 5 and is held firmly by means of a pair of similar sheet-metal clips A and B. Each of these is stamped out so as to form a medial or body portion 6, which bears against the front or rear face of the cross-bar and brace, a tongue being cut out and bent at right angles, as shown, the opening 8 thereby formed serving to receive the upright bar 2, while the tongue is secured upon the top or bottom face thereof, as shown in Fig. 4, by any suitable means, such as a screw-eye 9. The upper and lower edges 10 and 11 of the clip B are folded at right angles and furnished with teeth 12 to be driven into the cross-bar 3 and brace 5, as shown. The clip A has its upper and lower edges bent with two right angles, as shown, so as to overlap and partially embrace the clip B and the bars 3 and 5, the clips thus together making a very firm and rigid lock for the crossed bars. At the end of each of the bars I provide a sheet-metal ferrule or thimble C, (shown in Figs. 6 and 7,) which is secured in place preferably by screw-eyes 13, the metal at the outer end being inturned to bear upon the end of the bar. The ferrule is also formed with a tongue 14, having a double bend, so as to offset it from the bar and serving as a hook upon which an eye or a ring 15, fastened to the edge of the cover 16, may be slipped, as shown in Fig. 6. This cover is made, preferably, of suitable flexible material, such as cloth, and while in shape conforming substantially to the lines connecting the ends of the frame-pieces is wider along the line of the cross-bar than the length of the cross-bar. It is preferably hemmed along its edges, and threaded into the hem is a wire or cord guy 17, to which are connected the rings 15, so that when the rings are all attached to their respective hooks the cords or wires are drawn taut and the cross-

bars of the frame thereby stayed and strengthened. The greater width of the cover is taken up by gathers or folds along the portions of the wires or guys which run to the top of the kite, as indicated by the shade-lines in Fig. 1. Consequently when the kite is held face downward in a horizontal position, as indicated in Figs. 2 and 3, the cloth sags downward, as shown, but when presented to the wind in service the pressure of the wind will cause the cloth to be bellied out in each triangle, as indicated by the dot-and-dash lines in Fig. 2. This slackness of the covering is especially designed to permit this bellying of the cover under the wind-pressure, so as to produce pockets which serve to steady and support the kite, particularly in light winds. The broken line 18 indicates the bridle, one end being connected to the lower end of the upright and the other at the point of connection between the cross-bar and upright. The line-cord 19 is connected at any suitable point in the loop of the bridle, as indicated in Fig. 2.

By means of this construction I produce a kite which may be manufactured and transported in knocked-down form and readily assembled by unskilled persons and which when put together can be readily sailed in very light winds and without a tail. Adjustment of the cross-bar at the high point indicated on the upright serves to cause the kite to sail very nearly in a horizontal position and increases its efficiency, although the cross-bar may be placed at a lower point and serve its purpose practically. It is also possible by this adjustment of the members forming the framework and the cover adjusted loosely thereon, as described, to dispense largely and sometimes wholly with the curvature of the cross-bar, although the best and most satisfactory results, particularly in strong winds, have been obtained with the cross-bar having a slight curvature.

As the parts are made up for assembling the clips A and B are secured around the cross-bar and its brace, leaving an opening through which the upright is thrust, one of its end ferrules having been temporarily detached, after which the tongues of the clips are secured to the upright and the ferrule replaced. The end of the bridle for attachment to the cross-bar is also preferably passed through the cover and knotted on each side thereof to prevent their being separated, the outer knot serving as securing means for the cover when the bridle is connected to the cross-bar in assembling the parts.

I claim—

1. A kite comprising crossed bars, guys connecting the ends of said bars, and a flexible covering wider than the frame secured along said guys and gathered near the medial line of the frame.

2. In a kite the combination with the upright frame-piece, of the curved cross-piece, its chord-brace, and the metal clip engaging

the cross-piece and brace, and the upright passed between the same.

3. A kite comprising crossed bars or extender members guys extending around the ends of said members to form therewith a frame, and a flexible covering the upper portion of which is wider than the frame secured to the ends of said members and along said guys and gathered at or near the top of the frame adjacent its medial line.

4. In a kite, in combination with the curved cross-bar, and its brace, substantially as described, the sheet-metal clip or coupling surrounding both cross-bar and brace and having an opening to receive the upright, and the integral tongues adapted to be secured to the upright when in position.

5. A kite comprising a forwardly-curved cross-piece, a chord-brace thereon, an interposed rectilinear upright, an interlocking device for said parts, and a flexible covering of materially-greater dimensions than the frame secured by its edges thereto and "gathered" adjacent the medial line, as and for the purposes specified.

6. A kite-frame comprising a forwardly-curved cross-piece a chord-brace, a rectilinear upright secured between and interlocked therewith, and a bow-string for determining and maintaining the curvature of the cross-piece.

7. In a kite in combination with the frame-pieces and covering, sheet-metal clips upon the extremities of the frame-pieces having tongues closed over the frame-piece end and a tongue with reverse bend serving as a lateral catch or hook to receive an eye upon the covering as and for the purposes specified.

8. A kite comprising a forwardly-curved cross-piece, a rectilinear upright secured thereto, guys passing around the ends of said parts and forming therewith a frame, and a flexible covering upon said frame of materially-greater width and gathered adjacent the medial line.

9. A kite comprising crossed extender members, guys passing therearound to form a symmetrical frame, a flexible covering secured by its edges to the ends of said members and along said guys, and gathered adjacent its medial line.

10. In a kite of the character described, the combination of crossed extender members, guys passing therearound to produce a symmetrical frame, a covering secured upon the frame, and means upon the covering whereby under the action of the wind said covering is adapted to have formed in it two concavities extending longitudinally of the upright extender member, substantially as specified.

Signed at New York city, New York, this 29th day of July, 1898.

WILLIAM A. EDDY.

Witnesses:

AUGUSTUS LEE, Jr.,
I. J. GERRY.