



# TECHNICAL NOTE

D-985

WIND-TUNNEL INVESTIGATION OF PARAGLIDER MODELS  
AT SUPERSONIC SPEEDS

By Robert T. Taylor

Langley Research Center  
Langley Air Force Base, Va.

NATIONAL AERONAUTICS AND SPACE ADMINISTRATION  
WASHINGTON

November 1961

[www.australian-hanggliders-history.com](http://www.australian-hanggliders-history.com)

[www.australian-hang-gliding-history.com](http://www.australian-hang-gliding-history.com)

NATIONAL AERONAUTICS AND SPACE ADMINISTRATION

TECHNICAL NOTE D-985

WIND-TUNNEL INVESTIGATION OF PARAGLIDER MODELS

AT SUPERSONIC SPEEDS

By Robert T. Taylor

SUMMARY

An investigation was made in the Langley Unitary Plan wind tunnel to determine the behavior of paraglider models at moderate to high supersonic speeds. The models were deployed from a sting in the supersonic stream and steady-state aerodynamic performance data were obtained. Maximum values of the lift-drag ratio were about 1.4 at a Mach number of 2.65 and about 1.2 at a Mach number of 4.65. The angles of attack over which the models could be flown were limited by unsteady behavior of the canopy.

INTRODUCTION

A number of preliminary wind-tunnel and free-flight investigations have indicated useful qualities of the paraglider. Reference 1 shows the results of preliminary wind-tunnel tests of the paraglider in combination with an aircraft or drone configuration at subsonic speeds. Reference 2 indicates successful subsonic free-flight tests of small-scale controlled paraglider models. Many applications of the paraglider concept require operation at subsonic speeds only whereas others require operation in supersonic flow. Reference 3 shows the results of some tests at a Mach number of 1.89 with the model keel fixed to the wind-tunnel balance. In an effort to determine the aerodynamic characteristics of a paraglider under conditions closely simulating steady flight the present investigation was undertaken. Models were deployed and flown in a supersonic stream at Mach numbers from 2.36 to 4.65 in order to provide some basis for the application of paragliders to missions involving operation at supersonic speed.

This paper then presents the results of an experimental wind-tunnel program to determine the aerodynamic characteristics of paraglider models at supersonic speeds. The tests were made in the Langley Unitary Plan wind tunnel at Mach numbers from 2.36 to 4.65.

L  
1  
4  
9  
0

WWW.CIVILAVIATIONUNIVERSITY.COM

## SYMBOLS

$C_D$	drag coefficient, $\frac{D}{qS}$
$C_L$	lift coefficient, $\frac{L}{qS}$
$D$	drag, lb
$L$	lift, lb
$(L/D)_{\max}$	maximum lift-drag ratio of test
$M$	free-stream Mach number
$q$	dynamic pressure, $\frac{1}{2}\rho V^2$ , lb/sq ft
$S$	vehicle wing area (fabric area), sq ft
$V$	velocity, ft/sec
$\alpha$	angle of attack of keel, deg
$\rho$	density, slugs/cu ft

## TESTS

Figure 1 is a sketch of the model showing construction and rigging details. The canopy materials used were a nonporous combination of parachute nylon to which was cemented 1/4-mil-thick aluminized Mylar (models I and II) and a sailcloth material weighing 1.5 ounces per square yard (model III) which was also relatively nonporous.

The tests were made in the Langley Unitary Plan wind tunnel over a Mach number range from 2.36 to 4.65. Figure 2 is a cutaway sketch of the balance housing and longitudinal control system used in the tests. The balance housing was attached to a strut which spanned the tunnel. The strut was bolted to sidewall plates attached to the tunnel walls. The pitch-control motor was operated from outside the tunnel and was used to adjust the model attitude in the tunnel by differentially pulling the keel lines of the model. The balance measured lift and drag of the model during tests. Photographs of the test setup are shown in figure 3.

During the tests the model was strapped to the sting while the supersonic flow was established and the model was then deployed. No dynamic measurements were taken during the model deployment. Figure 4 illustrates the test conditions  $q$  and  $\alpha$  as functions of Mach number under which the data were obtained. The Reynolds number per foot of the investigation ranged from  $0.58 \times 10^6$  at  $M = 2.36$  to  $0.55 \times 10^6$  at  $M = 4.65$ .

Figure 5 is a schlieren photograph of model III during the test. No correction was made to the data due to the interference of the strut. Drag tares were run on the balance housing with the paraglider off and the drag measurements were corrected for these tares.

### DISCUSSION

Since the rigging of the paraglider models was different (fig. 1(b)) no direct comparisons between the data should be made concerning the effect of canopy material. Deployments were successful with this rigging provided the angle of attack at deployment was within the limits shown on figure 4. No attempt was made during these tests to attain the optimum rigging for best performance or stability over a wider angle-of-attack range. A motion-picture film supplement has been prepared and is available on loan. A request card form and a description of the film will be found at the back of this paper, on the page immediately preceding the abstract pages.

The basic data are presented in figure 6 where angle of attack and drag coefficient are plotted as a function of lift coefficient for the Mach numbers of the tests. These tests are summarized in figure 7 which shows  $(L/D)_{\max}$  as a function of Mach number. Values of  $(L/D)_{\max}$  range from about 1.4 at  $M = 2.65$  to about 1.2 at  $M = 4.65$  for the models tested. Tests at subsonic speed have shown dynamic pressure to have a pronounced effect on  $(L/D)_{\max}$ . Unpublished data from subsonic tests at dynamic pressures of 100 lb/sq ft and 4 lb/sq ft are also summarized in figure 7. It will be noted that changing  $q$  from 100 lb/sq ft to 4 lb/sq ft caused an increase in  $(L/D)_{\max}$  from 2.9 to about 4.2. Whether this observed effect of dynamic pressures on  $(L/D)_{\max}$  at subsonic speed will be in evidence at supersonic speed is not certain; however, it seems reasonable that a given glider will have more span and a modified twist and camber distribution at lower dynamic pressures.

The angle-of-attack limits, both upper and lower, indicated in figure 4 were dictated by the unsteady behavior of the glider canopy at the tunnel conditions of these tests. At the high angle-of-attack limit of

the tests the models were observed to have a symmetric oscillation of the leading edges as indicated in the following sketch:

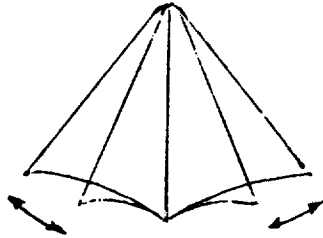

The mechanism of this unsteady behavior and its implication for full-sized gliders in free flight is unknown at this time. Because of the preliminary nature of the present investigation exhaustive determination of canopy behavior in this region was not made. The lower angle-of-attack boundary in figure 4 was imposed by a looseness of the canopy itself which showed up as a "flag waving" oscillation during the tests. Samples of both of these oscillations are shown in a high-speed schlieren film supplement to this paper along with a typical deployment at  $M = 2.65$ .

#### CONCLUDING REMARKS

An investigation was made in the Langley Unitary Plan wind tunnel to determine the behavior of paraglider models at moderate to high supersonic speeds. The models were deployed in the supersonic stream and aerodynamic performance data were obtained. Maximum values of the lift-drag ratio were about 1.4 at a Mach number of 2.65 and about 1.2 at a Mach number of 4.65. The angles of attack over which the models could be flown were limited by unsteady behavior of the canopy.

Langley Research Center,  
National Aeronautics and Space Administration,  
Langley Field, Va., September 13, 1961.

## REFERENCES

1. Naeseth, Rodger L.: An Exploratory Study of a Parawing as a High-Lift Device for Aircraft. NASA TN D-629, 1960.
2. Hewes, Donald E.: Free-Flight Investigation of Radio-Controlled Models with Parawings. NASA TN D-927, 1961.
3. Rogallo, Francis M., Lowry, John G., Croom, Delwin R., and Taylor, Robert T.: Preliminary Investigation of a Paraglider. NASA TN D-443, 1960.

L  
1  
4  
9  
0

[www.australian-hang-gliding-history.com](http://www.australian-hang-gliding-history.com)

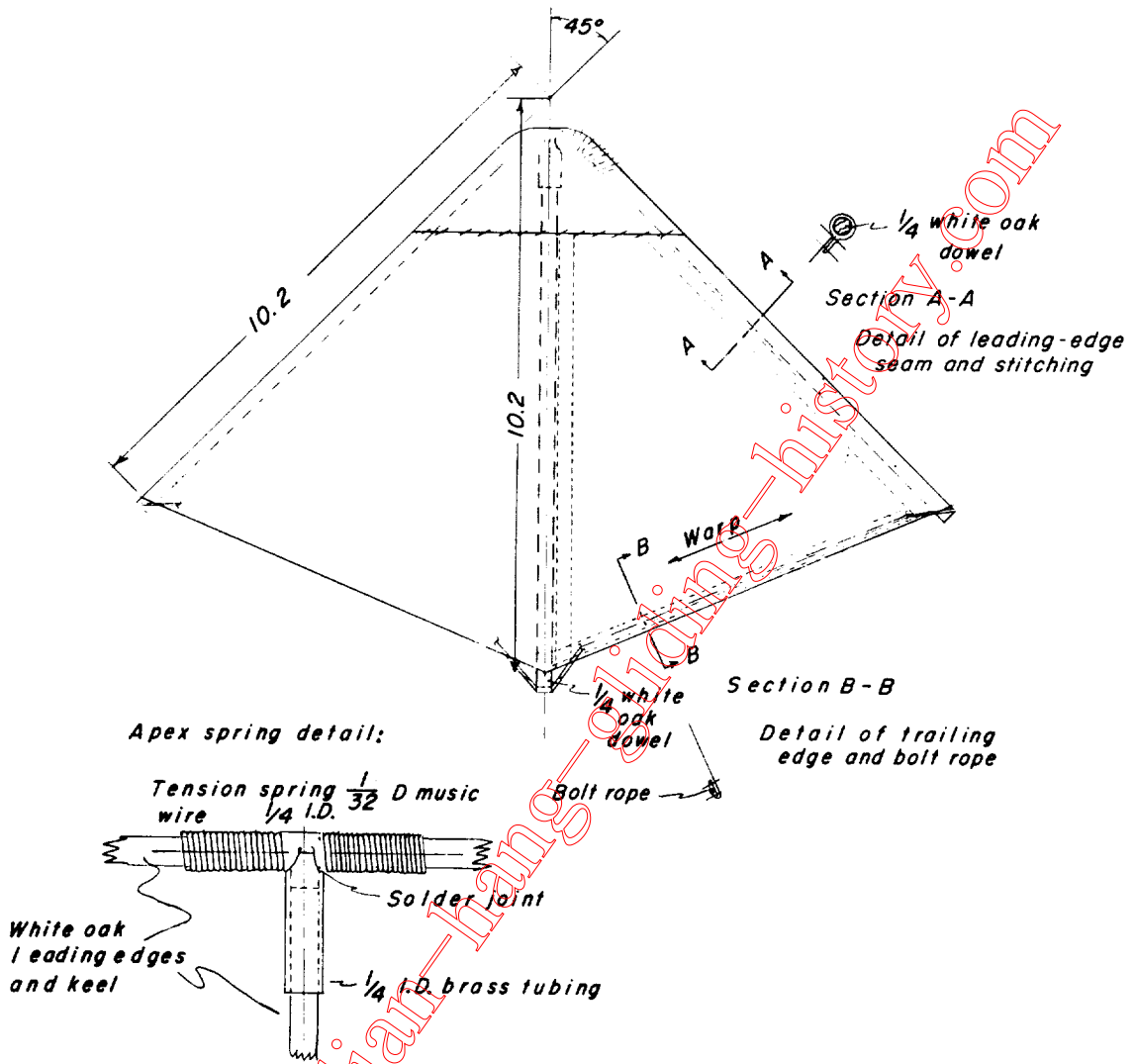

(a) Parawing construction.

Figure 1.- Details of parawing construction and rigging. All dimensions are in inches unless otherwise noted.

I-1490

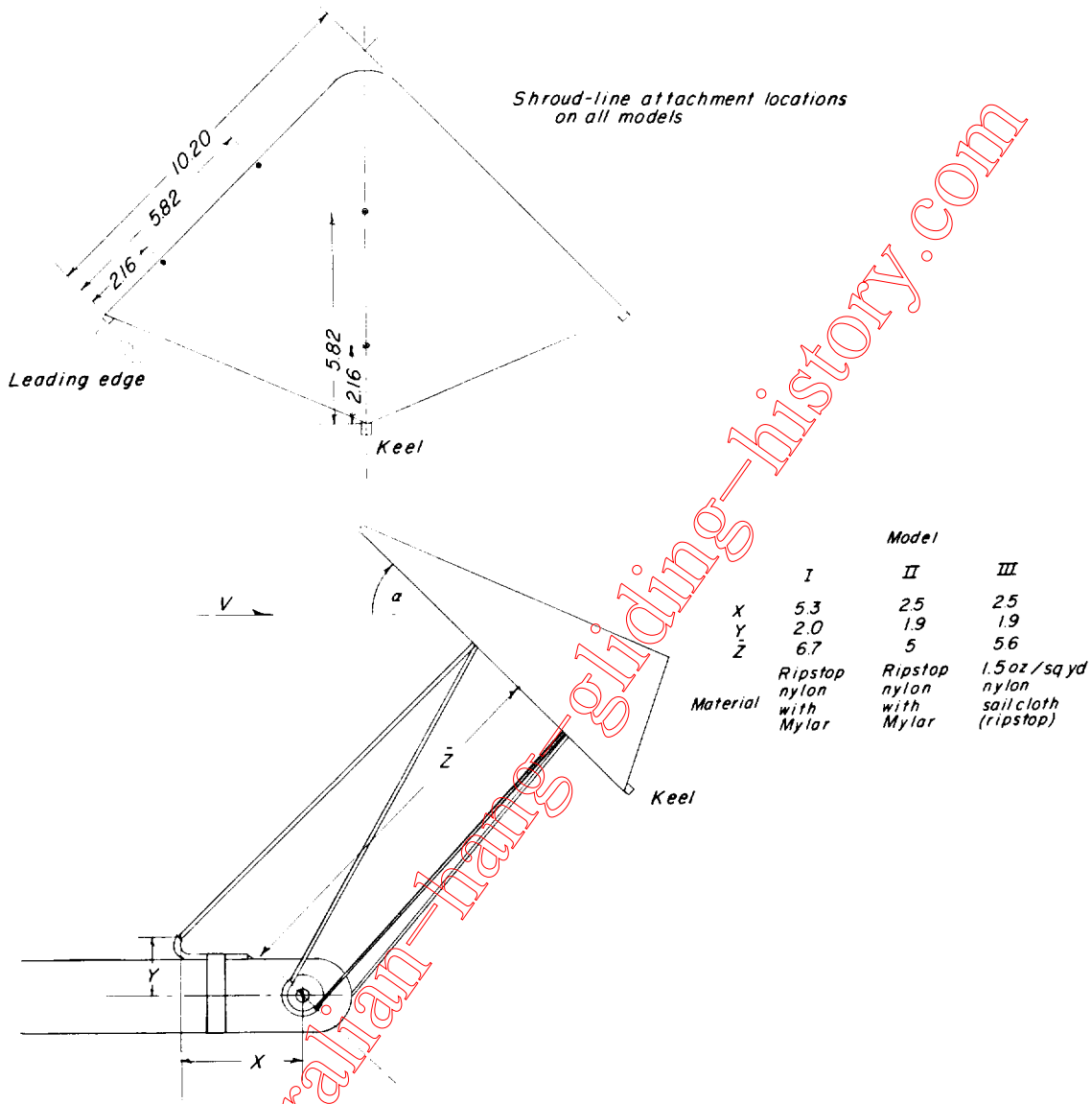

(b) Parawing rigging.

Figure 1.- Concluded.

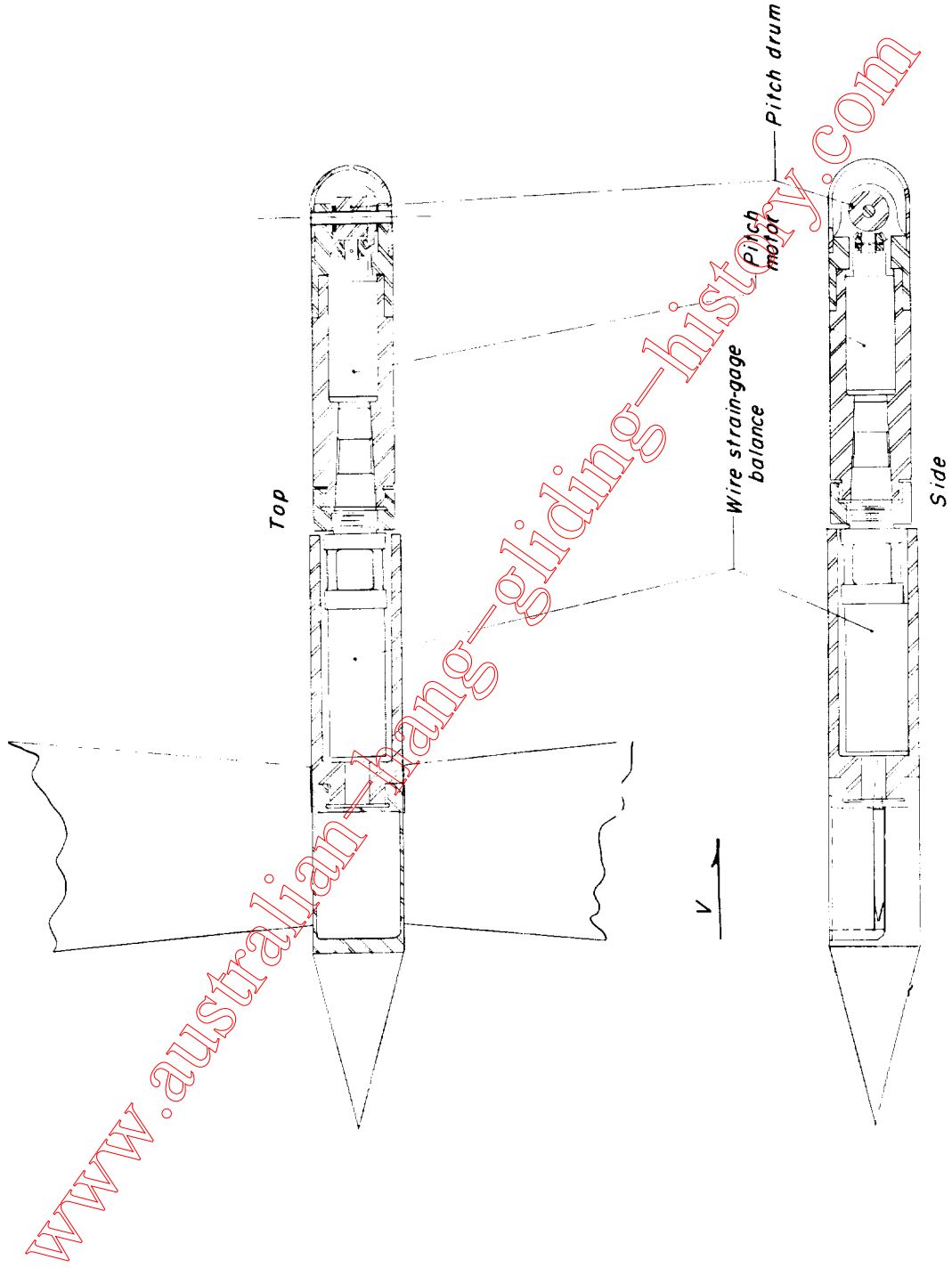

Figure 2.- Cutaway of model support apparatus.



(a) Model position prior to release.

I-60-2078.1

Figure 3.- Photographs of model and test setup in Langley Unitary Plan wind tunnel.



(b) Model position after release (keel lines not shown). I-60-2080

Figure 3.- Concluded.

L-1490

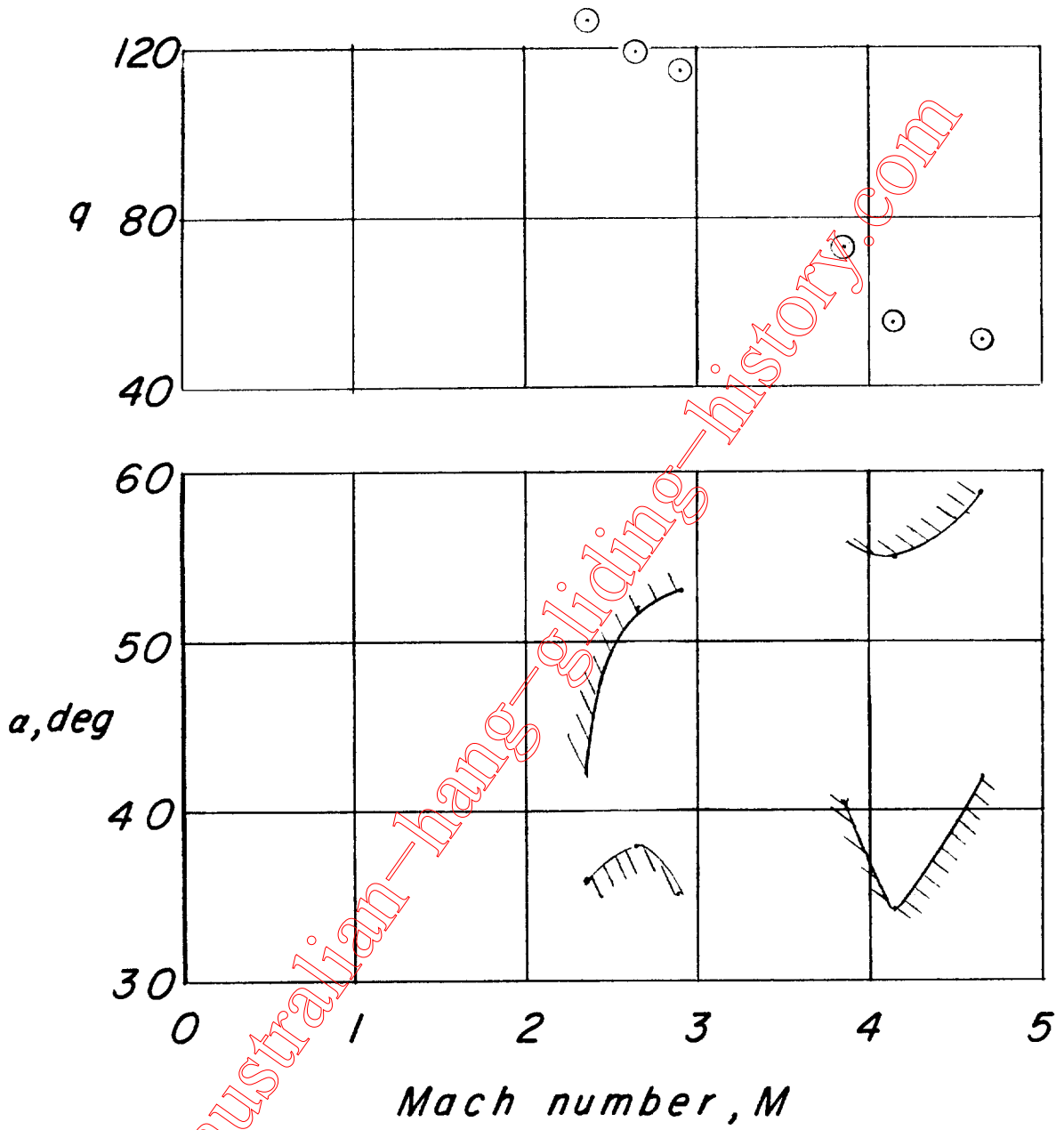
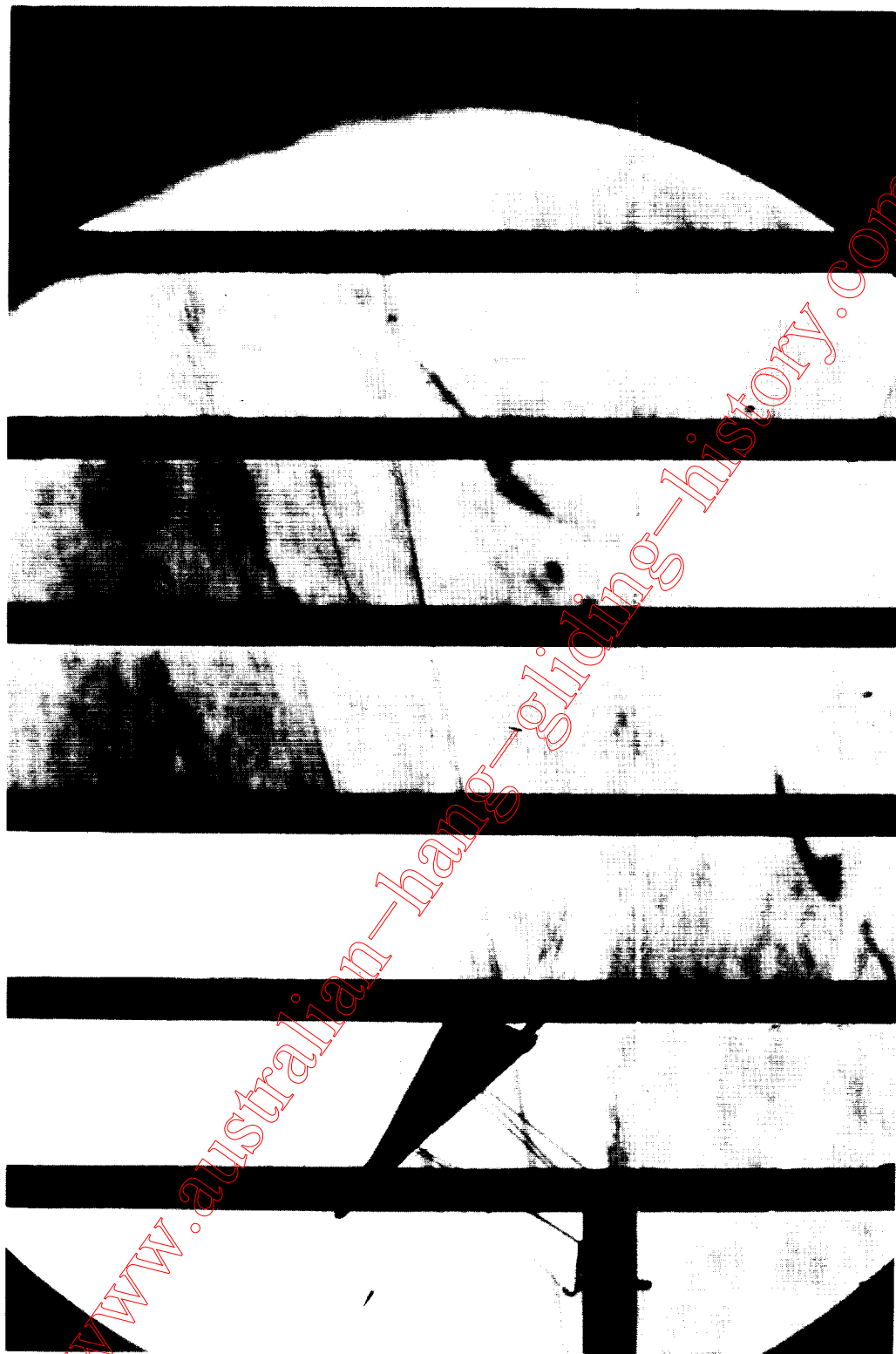

Figure 4.- Variation of the test conditions over which data were obtained.



L-61-5085

Figure 5.- Schlieren photograph of model III flying in Langley Unitary Plan wind tunnel.

$M = 4.65$ ;  $q = 50$ ;  $\alpha = 46^\circ$ .

L-1490

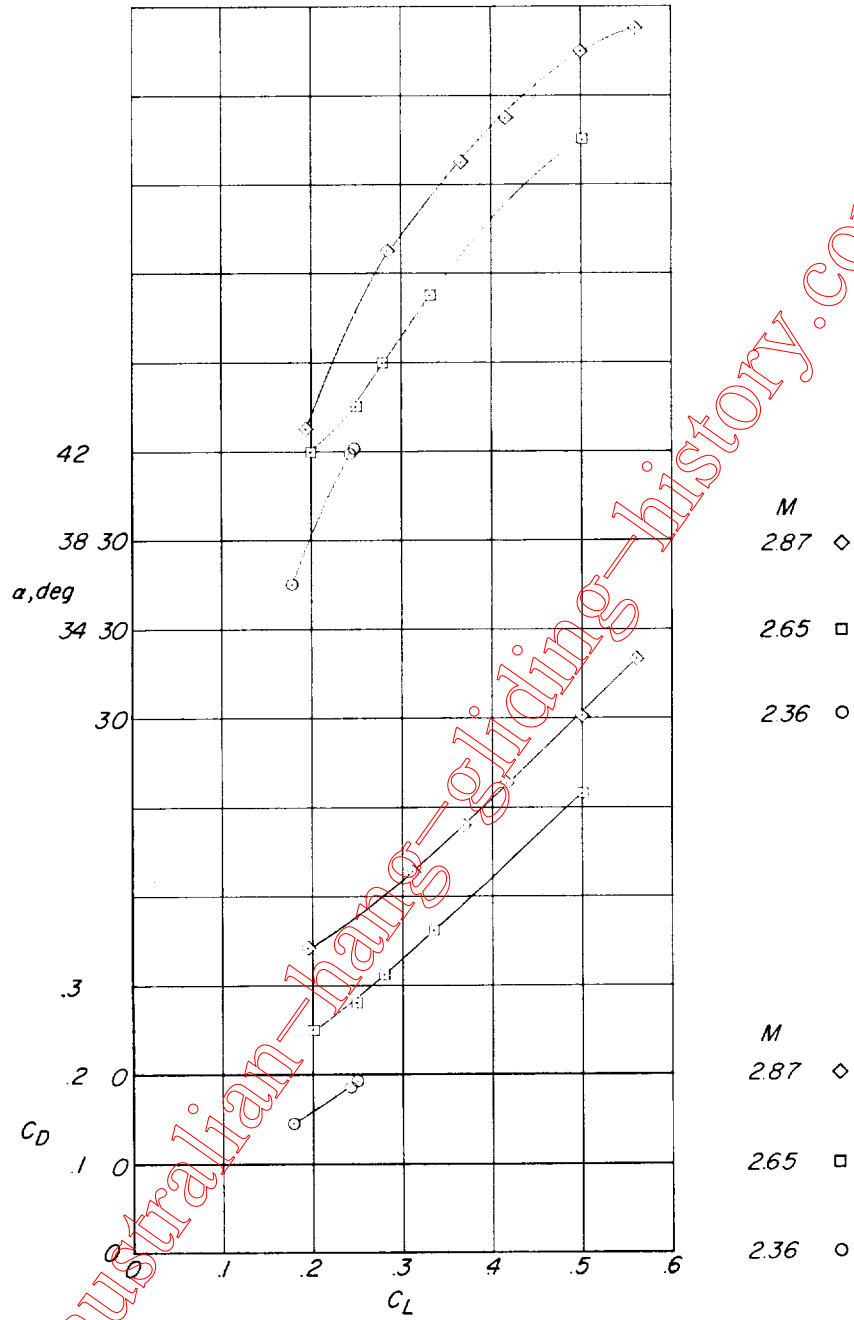

(a) Model I.

Figure 6.- Variations of angle of attack and drag coefficient with lift coefficient.

www.australian-hang-gliding-history.com

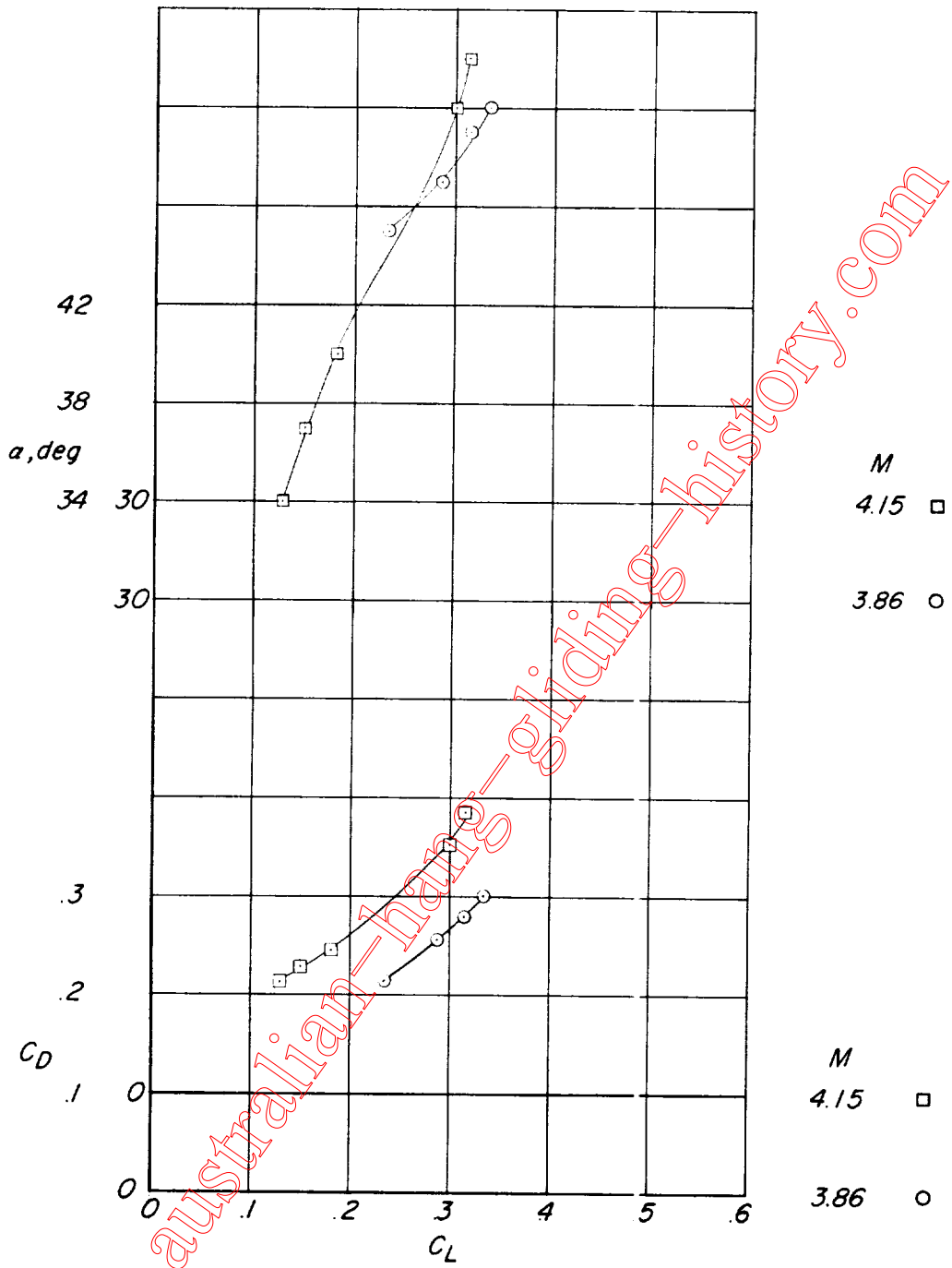

(b) Model II.

Figure 6.- Continued.

L-1490

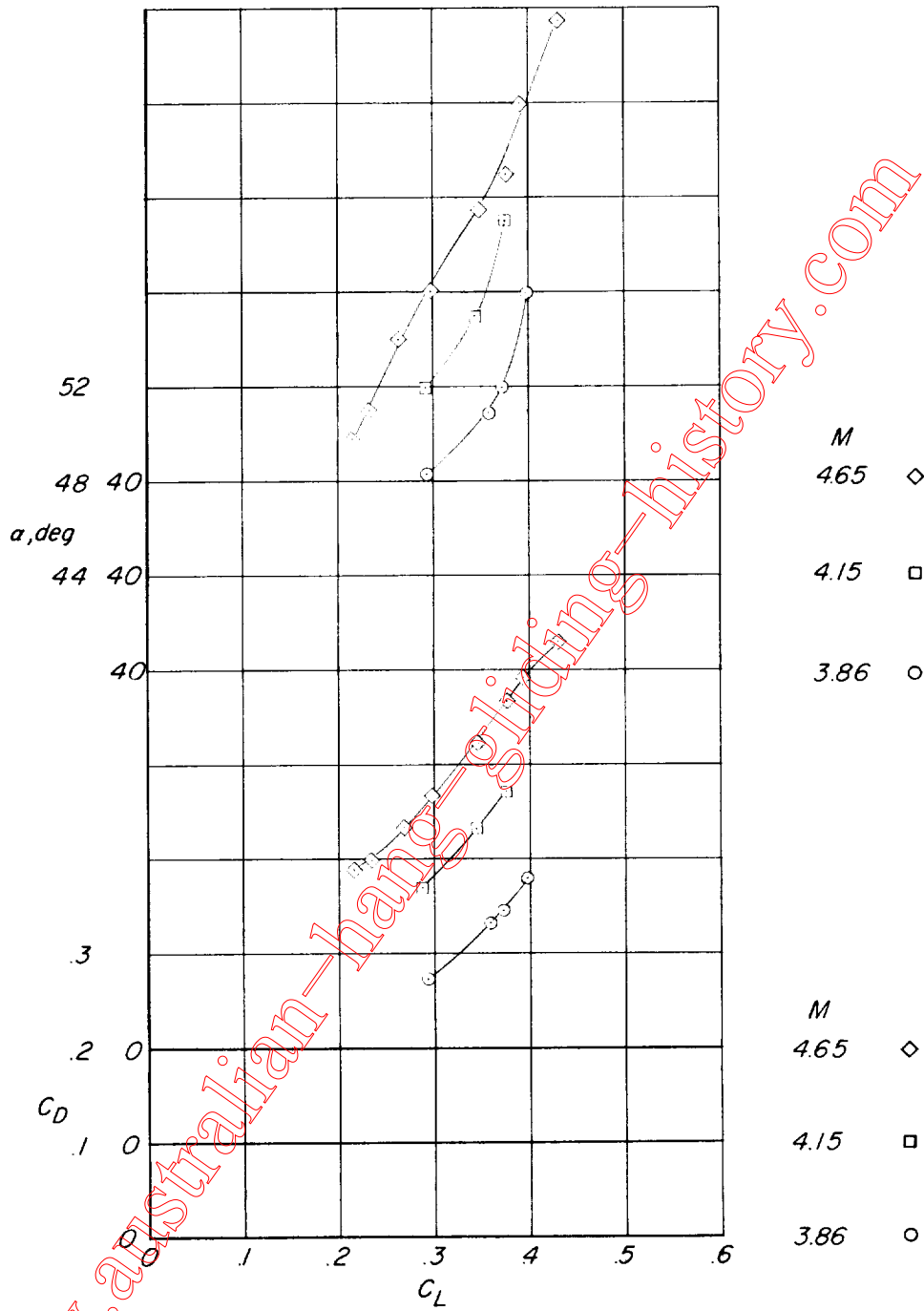

(c) Model III.

Figure 6.- Concluded.

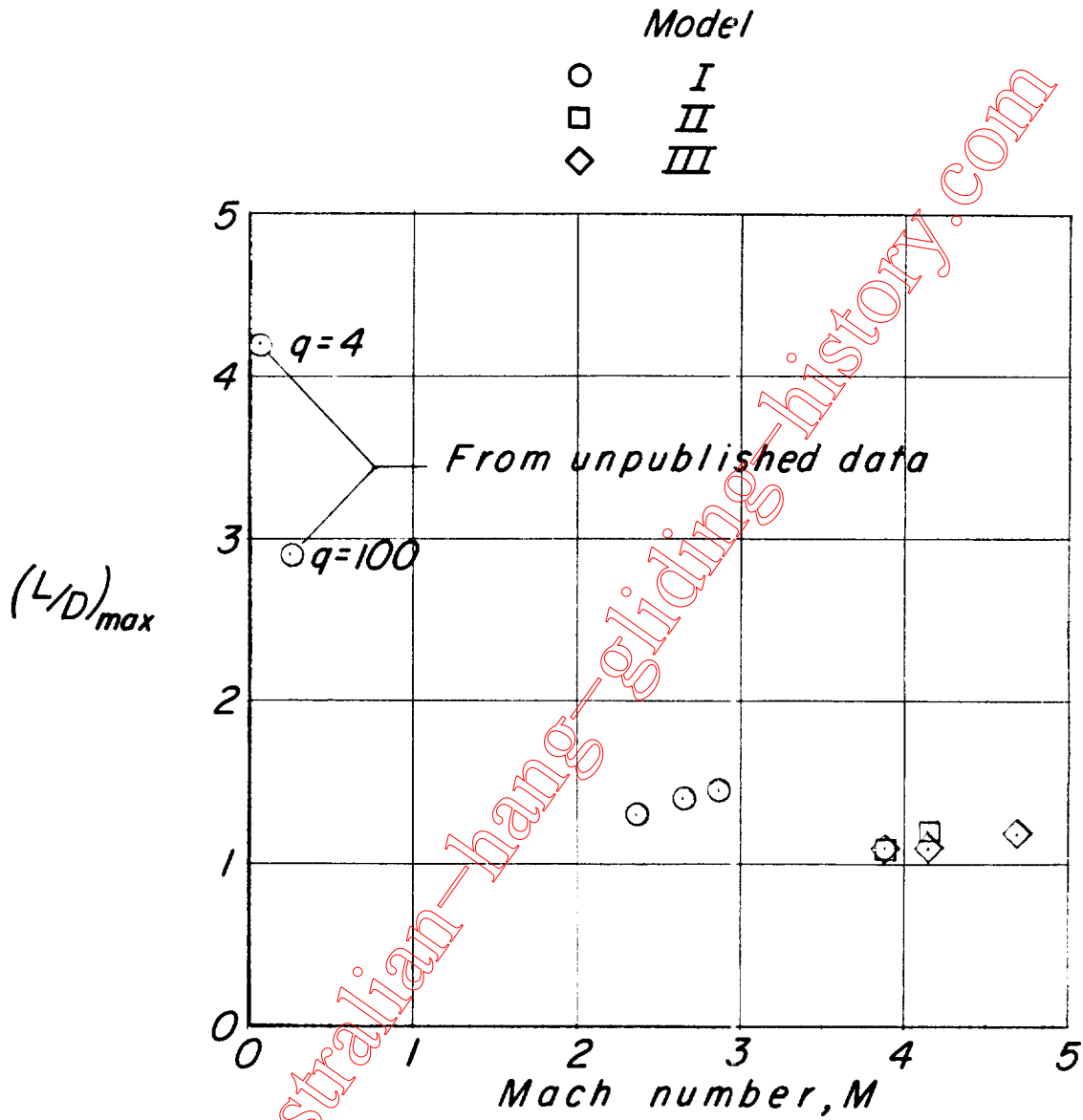

Figure 7.- Maximum lift-drag ratio as a function of Mach number.

www.australian-hang-gliding-history.com